

HOLMAN

ASPECT

Wi-Fi  Solar Pro

WS5091W



Contents

Introduction	2
Overview	4
Main Console	4
LCD Display	5
Wireless Hygro-Thermo Indoor Sensor	5
6-in-1 Wireless Outdoor Sensor	6
Installation and Setup	7
Wireless Hygro-Thermo Indoor Sensor	7
6-in-1 Wireless Outdoor Sensor	7
Main Console	8
Wi-Fi Connection Setup	9
Wi-Fi Setup Requirements	11
Operation and Settings	11
Time and Date	11
Viewing Live Weather Data	11
Moon Phase	12
Sunrise and Sunset Time	12
Wi-Fi Connection Status	12
Time Server Connection Status	12
Setting Date and Time	13
Setting Alarm Time	13
Temperature Pre-Alarm Function	14
Indoor/Outdoor Temperature and Humidity	14
Wind	15
Weather Index	15
Weather Forecast	18
Barometric Pressure	19
Rainfall	19
History Graph	20
Weather Alert Setting	21
Pointing Outdoor Sensor to South	22
Maintenance	22
Battery Replacement	22
Cleaning the Rain Collector	23
Cleaning the Outdoor Hygro-Thermo Sensor	23
Cleaning The UV Sensor and Calibration	23
Main Console Firmware Update	23
Precautions	24
Specifications	25

Introduction

Thanks for choosing our **Aspect Wi-Fi Solar Pro**. This system gathers and automatically uploads accurate and detailed weather data to [Weather Underground](#), which allows weather observers to upload their local weather data. This product offers professional weather observers or serious weather enthusiasts robust performance with a wide range of options and sensors.

You will get your own local forecast, high/low, totals or averages and graphs for virtually all weather variables without using a desktop computer.

The **Aspect Wi-Fi Solar Pro** includes a **6-in-1 Wireless Outdoor Sensor** which transmits outdoor temperature, humidity, wind speed, wind direction, rainfall and UV with solar power. Also, the included wireless indoor sensor, transmits your indoor temperature and humidity to the **Main Console**. Both sensors are fully assembled and calibrated for your easy installation. They send data at a low power radio frequency to the **Main Console** from up to 150m away (line of sight).

In the **Main Console**, a high-speed processor is embedded to analyse weather data and publish it to [Weather Underground](#) through your home Wi-Fi router. The **Main Console** can also synchronise with an internet time server to keep the time and weather data time stamp of high precision. The wide-viewing-angled with high-contrasted LCD display shows informative weather readings with advanced features, such as high/low alert alarm, different weather index, multi-functional bar chart and maximum/minimum records. With the built-in sunrise/sunset and moon phase feature, this system is truly a personal yet professional weather station for your own backyard.

i This instruction manual contains useful information on the proper use and care of this product. Please read this manual through to fully understand and enjoy its features, and keep it handy for future use.

Overview

Main Console

1. **BAROMETER**
2. **WIND**
3. **ALARM/SNOOZE**



4. **INDEX**
5. **RAINFALL**
6. LCD display
7. **GRAPH** ^
8. °F/°C v
9. **HISTORY**



10. **MAX/MIN**
11. **CHANNEL**
12. Status LED
13. Wall mount
14. **REFRESH**
15. **Wi-Fi/SENSOR**

16. **CLOCK SET**
17. **ALARM**
18. **ALERT**

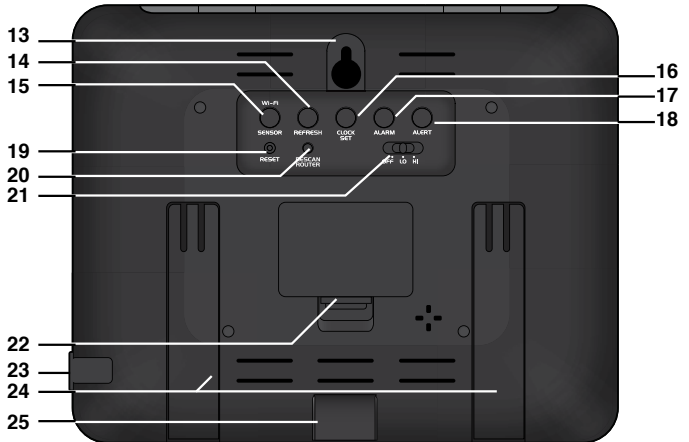

19. **RESET**
20. **RESCAN ROUTER**
21. Backlight dimmer
22. Battery compartment
23. USB socket (firmware update only)
24. Table stand
25. Power jack

Overview (continued)

LCD Display

1. Outdoor temperature and humidity
2. Indoor temperature and humidity
3. Calendar and moon phase
4. Wind direction and speed
5. Weather index
6. Time, sunrise/sunset and system status
7. Weather forecast
8. Barometer
9. Rainfall
10. Multi-function historical bar chart

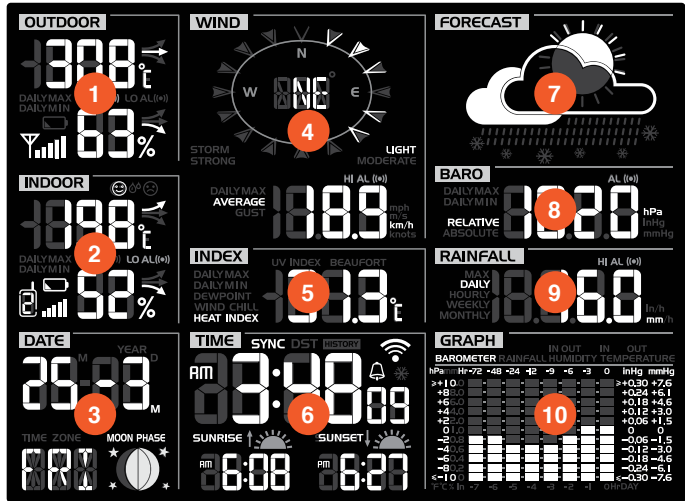

Wireless Hygro-Thermo Indoor Sensor

1. Transmission status LED
2. Wall mount
3. Channel slider
4. Reset
5. Battery compartment

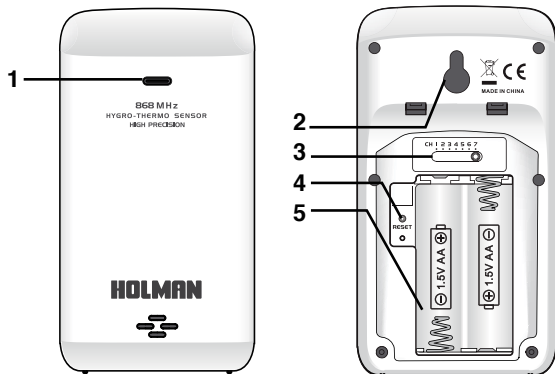

Overview (continued)

6-in-1 Wireless Outdoor Sensor

1. Wind vane
2. Wind cups
3. Antenna
4. Louvre shield
5. Pole mount (fit 35~40mm pole, not included)
6. Hygro-Thermo sensor
7. Battery door
8. Reset
9. Transmission status LED
10. Level gradienter
11. Rain collector
12. UV sensor
13. Solar panel

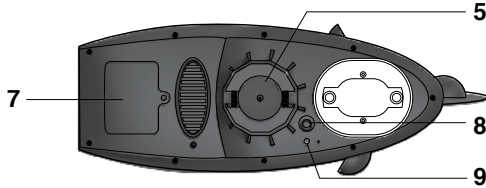
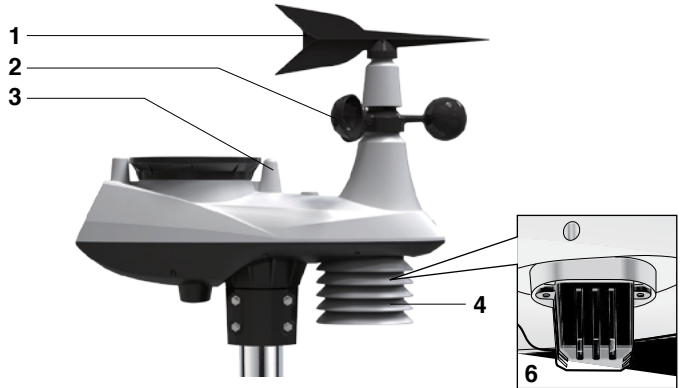

Installation and Setup

Wireless Hygro-Thermo Indoor Sensor

Pairing with the Main Console:

1. Remove the battery door of the sensor.
2. Insert 2 × AA size batteries into the battery compartment. Make sure you insert them the right way according to the polarity information marked on the battery compartment.
3. Close the battery door. The transmission status LED will begin to flash every minute.

- i** If you need to re-assign the sensor channel, firstly slide the channel slide switch to the new channel, press **SENSOR** on the **Main Console**, and then press **RESET** on the **Wireless Hygro-Thermo Indoor Sensor** to pair them again.
- i** Avoid placing the sensors in direct sunlight, rain or snow.
- i** To avoid the sensors and **Main Console** pairing failure, please power up the sensors first, and then press **RESET** on the **Main Console** (no need on sensors).

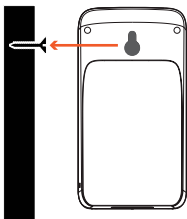

Placing the sensor: Place a screw on the wall that you wish to hang the sensor on. Hang the sensor onto the screw by the wall mounting holder. You can also place the sensor on a table by itself.

6-in-1 Wireless Outdoor Sensor

Your wireless outdoor sensor measures Wind Speed, Wind Direction, Rainfall, UV Index, Temperature and Humidity for you.

Pairing the 6-in-1 Wireless Outdoor Sensor with the Main Console:

1. Unscrew the battery door at the bottom of the unit and insert the batteries according to the polarity information marked on the battery compartment.

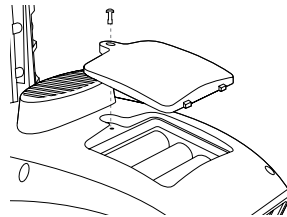

2. Screw on tightly.
 3. Once the batteries are installed, the transmission status LED will begin to flash.
- i** Ensure the battery door screw locked well.
 - i** Ensure the transmission status LED is flashing every 12 seconds.

Installing the 6-in-1 Wireless Outdoor Sensor:

Install in an open location with no obstructions above and around the sensor for accurate rain and wind measurement.

To insure a tight grip, apply the rubber pads provided before fastening the mounting base to the pole or post (not included).

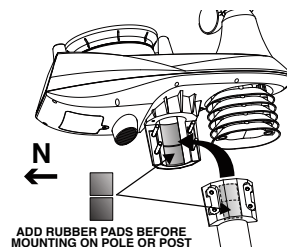

Installation and Setup (continued)

6-in-1 Wireless Outdoor Sensor (continued)

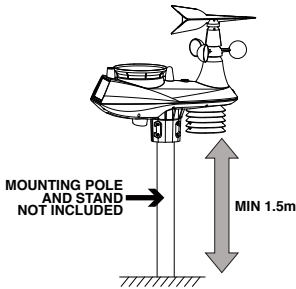

Mounting guideline:

1. Install the sensor at least 1.5m off the ground for better and more accurate wind measurements.
2. Choose an open area within 150m from the **Main Console**.
3. Install as level as possible to achieve accurate rain and wind measurements. Use the level indicator on the top to ensure a level installation.
4. Mount with the solar panel end pointing to North to correctly orient the direction of the wind vane.

Main Console

Backup battery installation: Remove the battery door, insert 3 new AAA batteries and then close the battery door.

Powering up the Main Console:

1. Plug the adaptor into the DC jack.
2. Press **RESET** to restart the **Main Console**.
3. After restart, all LCD segments will show. The **Main Console** will enter **AP (Access Point) Mode** and the status LED will turn green.

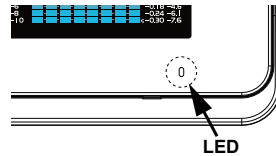

- i** The **Main Console** LED can show the following:
 - Green light, flashing:** **AP Mode** for setup
 - Blue light, solid:** Connected to Wi-Fi
 - Blue light, flash:** Searching for Wi-Fi
 - Red light, flash:** Firmware update
 - Cyan light, flash:** Manual sensor pairing
 - Purple light, flash:** Data/time refreshing

- i** This **Main Console** has a dual backup system which allows you to backup different settings and history records:

Battery backup:

- ✓ Time and date
- ✓ Max/Min records
- ✓ Alert setting values
- ✓ Bar chart records
- ✓ Past 24hr records

Built-in backup:

- ✓ Router settings
- ✓ Weather server
- ✓ Time server
- ✓ Latitude/longitude
- ✓ Time zone
- ✓ Channel history

Installation and Setup (continued)

Main Console (continued)

Setting the Main Console time zone:

The **Main Console** will synchronise the clock with the UTC time server once you set the time server and connected to the internet. In order to display the correct time and activate the sunrise/sunset function, you need to set the correct time zone:

1. Press and hold **CLOCK SET** for 2 seconds to enter time zone setting in **Time Setting Mode**.
2. Press **▲** or **▼** to select the correct time zone.
3. Press **CLOCK SET** again to enter the next setting.
4. The setting sequence:
TIME ZONE > DST ON/OFF > HOUR > MINUTE > SECOND > 12/24 HOUR FORMAT > YEAR > MONTH > DATE > M-D/D-M FORMAT > TIME SYNC ON/OFF > LANGUAGE
5. Press **CLOCK SET** to save and exit, or the unit will automatically exit 60 seconds later without pressing any button.

Pairing sensors with the Main Console: The **Main Console** will automatically search and connect to your wireless indoor and outdoor sensor. You can also press **Wi-Fi/SENSOR** to search for your sensors manually. Once your sensors pair up successful, the sensor signal strength indication and weather information will appear on your **Main Console** display.

- ❶ The status LED will flash cyan, once you press **Wi-Fi/SENSOR** to search the sensors manually.

Wi-Fi Connection Setup

- ❶ To connect the **Aspect Wi-Fi Solar Pro** to Wi-Fi, it must be registered with [Weather Underground](#).
- ❷ [Weather Underground](#) setup instructions are correct as of January 2019. Refer to <https://www.wunderground.com/> for details if their registration process has changed.

Register your Aspect Wi-Fi Solar Pro with [Weather Underground](#):

1. Visit <https://www.wunderground.com/> and click **JOIN** in the top right corner and follow the prompts to create an account. Note that your email address must be validated by [Weather Underground](#) before proceeding. If you already have an account with [Weather Underground](#) you can simply **LOG IN**.
2. After logging in to your account, click **MY PROFILE** and select **MY WEATHER STATIONS** in the menu. On the following page, click **ADD A NEW PWS**.
- ❶ On the next page, note **it is essential** to jot down the **LONGITUDE/LATITUDE** for your reference later.
3. After noting the **LONGITUDE/LATITUDE**, follow the prompts to complete registration of your **Aspect Wi-Fi Solar Pro** with [Weather Underground](#).
- ❷ After submitting your details, note **it is essential** to jot down your **STATION ID** and **STATION KEY/PASSWORD**.

Set the Main Console to transmit weather data to [Weather Underground](#):

4. Plug the adaptor into the DC jack to power up the **Main Console** for the initial start-up. The status LED on the **Main Console** will flash green light to signify that it has entered into the **AP Mode**.
- ❶ You can also access **AP Mode** by holding the **Wi-Fi / SENSOR** key for 6 seconds in **Normal Mode**.
5. Use your Wi-Fi enabled device to connect to the **Main Console** SSID: PWS-XXXXXX.

Installation and Setup (continued)

Wi-Fi Connection Setup (continued)

- Once connected, open the web browser on your device, type **192.168.1.1** into the address bar and press **ENTER** to access the **Main Console** setup interface.
- Fill in the connection information for the setup interface. Your **Aspect Wi-Fi Solar Pro** will use this information to connect your Wi-Fi router.

- Setup interface will differ depending on your web browser.
- This requires **STATION ID**, **STATION KEY/PASSWORD** and **LONGITUDE/LATITUDE** as outlined in previous steps.

The screenshot shows the 'WiFi Router setup' section of the Main Console interface. It includes a 'Language' dropdown set to 'English'. Below it are fields for 'Router' (a dropdown menu showing 'ROUTER_A'), 'Add Router' (a text input field), 'Security type' (a dropdown menu showing 'WAP2'), and 'Router Password' (a text input field with a password icon). The 'Weather server setup' section has 'Web server URL' (a text input field showing 'rtupdate.wunderground.com'), 'Station ID' (a text input field), and 'Station key' (a text input field with a password icon). The 'Time server setup' section has 'Server URL' (a dropdown menu showing 'nist.time.gov'). The 'Location setup' section has 'Latitude' (a text input field showing '0.00') and 'Longitude' (a text input field showing '0.00'), each followed by a direction dropdown menu (showing 'North' and 'East' respectively). An 'Apply' button is at the bottom right. The firmware version '1.00' is shown at the bottom left. Annotations with arrows point to various fields: 'ROUTER_A' (Select the Wi-fi router (SSID) you will connect to), the 'Add Router' field (Manually enter the SSID if it is not on the list), 'WAP2' (Select router's security type (usually WAP2)), the 'Router Password' field (Enter your router password), the 'Station ID' field (Enter the "Station ID" assigned by Wunderground), the 'Station key' field (Enter the "Station key" assigned by Wunderground), the 'North' dropdown (Select the direction (e.g. EU countries Longitude is East and US is West)), and the '0.00' text input fields (Enter the latitude and longitude with 3 decimal places).

- Click **APPLY** to finish the setup. If all the information you entered is correct, the **Main Console** LED will change to solid blue.
 - If the LED does not change to solid blue, please check your details and correct them accordingly.

- Once setup is complete, the **Main Console** will disconnect the Wi-Fi from your device and search for the router that you have assigned. If the connection is successful, the status LED on the **Main Console** will change to blue and the Wi-Fi icon will show on the LCD without flashing.

Installation and Setup (continued)

Wi-Fi Setup Requirements

Device requirements:

- ✔ Device with built-in Wi-Fi and **AP Mode** function, running **Windows**, **macOS**, **iOS** or **Android**
- ✔ **Wi-Fi Standard:** 802.11 b/g/n, supports **AP Mode**
- ✔ Web browser that supports **HTML5**

Router requirements:

- ✔ **Wi-Fi Standard:** 802.11 b/g/n
- ✔ **Security type:**
WEP/WPA/WPA2/
open (for routers with no password)

Viewing Live Weather Data

1. To view live data from the wireless outdoor sensor in a web browser, visit <https://www.wunderground.com/>, and enter your **STATION ID & KEY** in the search box. Weather information will show on the next page.

Operation and Settings

Time and Date

















The **TIME** and **DATE** information windows are located at the bottom left of the **Main Console** display. You can view all the time related information and **Main Console** status in these two sections.



Operation and Settings (continued)

Moon Phase

The **Moon Phase** is determined by the time, date and time zone. The following table explains the moon phase icons of the Northern and Southern hemispheres. Please refer to **Pointing the 6-In-1 Outdoor Sensor Towards South** section about how to setup for the Southern hemispheres.



Northern hemisphere	Moon Phase	Southern hemisphere
	New Moon	
	Waxing Crescent	
	First quarter	
	Waxing Gibbous	
	Full Moon	
	Waxing Gibbous	
	Third quarter	
	Waxing Crescent	

Sunrise and Sunset Time

The **Main Console** indicates your sunrise and sunset time by the time zone, latitude and longitude you entered. Please insert the correct information in the regarding settings. If the latitude and longitude values do not match the time zone, the sunrise and sunset time cannot be shown.



Wi-Fi Connection Status

As soon as the **Main Console** successfully connects to the Wi-Fi router, the Wi-Fi signal icon  will appear on the LCD display. If the Wi-Fi signal is not stable or the **Main Console** is trying to connect to the router, the icon  will flash. If the icon  disappears, it means the **Main Console** cannot connect to the Wi-Fi router or enter the **AP Mode**.

Time Server Connection Status















After the **Main Console** has connected to the internet, it will attempt to connect to the internet time server. Once the connection succeeds and the time is updated, the **SYNC** icon will appear on the **Main Console**. The time will automatically sync to the internet time server at noon and midnight daily, or manually within 1 minute by pressing **REFRESH**.

Operation and Settings (continued)

Setting Date and Time

The **Aspect Wi-Fi Solar Pro** is designed to obtain the local time from and to sync with the assigned internet time server. If you want to use this device offline, you can set the time and date manually:

1. In **Normal Mode**, press and hold **CLOCK SET** for 2 seconds to enter **Date and Time Setting Mode**.
2. Press **GRAPH ^** or **°F/°C v** to adjust the value, or press and hold to change rapidly.
3. While in **Date and Time Setting Mode**, press **CLOCK SET** key to switch to the next setting.
4. The setting sequence is:
TIME ZONE > DST ON/OFF > HOUR > MINUTE > SECOND > 12/24 HOUR FORMAT > YEAR > MONTH > DATE > M-D/D-M FORMAT > TIME SYNC ON/OFF > LANGUAGE
5. After completing the language setting, press **CLOCK SET** to save and exit.

TIME ZONE setting	 00H → 01H...23H → -23H...-01H → 00H	
DST ON/OFF setting		
Hour > Minute > Second setting	 →  → 	
12/24Hr setting	 / 	
Year > Month > Day setting	 →  → 	
M-D/D-M setting	 Month-Day /  Day-Month	
Internet time sync		Language  EN ↔ FR ↔ DE ↔ ES ↔ IT ↔ NL ↔ RU ↔ EN

Setting Alarm Time

1. In **Normal Time Mode**, press and hold **ALARM** for 2 seconds until the alarm hour digit flashes to enter **Alarm Time Setting Mode**.
 2. Press **^** or **v** to adjust the value. The setting sequence is: **HOUR > MINUTE**
 3. Press **ALARM** to save and exit.
- i** The alarm icon  will show when alarm is set.
 - i** Press **ALARM/SNOOZE** to stop the alarm and enter snooze. The alarm will sound again after 5 minutes. The alarm will stop automatically without pressing any button in 2 minutes.
 - i** Hold **ALARM/SNOOZE** for 2 seconds to stop alarm.

Operation and Settings (continued)

Temperature Pre-Alarm Function

- In **Normal Mode**, press **ALARM** key to show the alarm time for 5 seconds.
 - When the alarm time displays, press **ALARM** again to activate the alarm function, or press **ALARM** *twice* to activate the alarm with ice pre-alarm function.
- i** Once the ice pre alert activates, the preset alarm will sound 30 minutes earlier if the outdoor temperature is below -3°C.

		
Alarm off	Alarm on	Alarm with ice-alert



Indoor/Outdoor Temperature and Humidity

- i** You can view the indoor/outdoor channel temperature and humidity readings and the related information at the top-left or middle left column of the LCD.
- i** In **Normal Mode**, press °F/°C to switch between °C/°F.
- i** Please locate the **Main Console** where it can receive good sensor signal from the **6-in-1 Wireless Outdoor Sensor**.

Wireless Outdoor Sensor Signal Strength:

		
No signal	Weak signal	Good signal

Wireless Indoor Sensor Signal Strength:

		
No signal	Weak signal	Good signal

Viewing Different Indoor Channel: The **Main Console** can pair with up to 7 wireless indoor Thermo-Hygro sensors. With 2 or more sensors, you can press **CHANNEL** key to switch between different indoor channels in **Normal Mode**, or press and hold **CHANNEL** key for 2 seconds to toggle **Auto-Cycle Mode** to display the connected channels at 4 second intervals. During **Auto-Cycle Mode**, press **CHANNEL** key to stop the auto cycle and display the current channel.

Comfort Indication: This is a pictorial indication based on indoor air temperature and humidity in an attempt to determine comfort level. Each indoor channel has independent comfort indication.

		
Too cold	Comfortable	Too hot

Operation and Settings (continued)

Indoor/Outdoor Temperature and Humidity (continued)

Temperature/Humidity Trend:

Arrow indicator			
Temperature / Humidity trend	Rising	Steady	Falling

i When temperature is below -40°C, the LCD will display **LO**. If temperature is above 80°C, LCD will display **HI**, when humidity is below 1%, LCD will display **LO**. If humidity is above 99%, LCD will display **HI**.

Wind

Viewing Wind Direction:

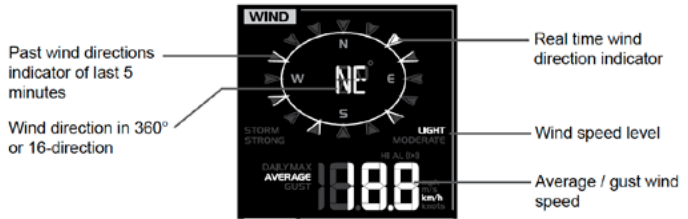

Select Wind Display Mode: In **Normal Mode**, press **WIND** to switch between **Average** wind speed and **Gust** wind speed.

Set Wind Speed Unit and Direction Display Format:

- In **Normal Mode**, press and hold **WIND** for 2 seconds to enter into **Wind Speed Unit Mode** and the unit will flash. And then press **▲** or **▼** to change wind speed unit in this sequence: **m/s > km/h > KNOTS > mph**
- Press **WIND** again to enter into **Wind Direction Display Format Setting Mode**. The wind direction reading will flash. And then press **▲** or **▼** to select display format between 360° and 16-direction.
- Press **WIND** again to return to **Normal Mode**.

Wind Speed Level:

Level	LIGHT	MODERATE	STRONG	STORM
Speed	0.1km/h ~19km/h	20km/h ~ 49km/h	50km/h ~ 88km/h	> 89km/h

Weather Index

In **Normal Mode**, press **INDEX** key to view the weather indices in this sequence:

**UV INDEX > BEAUFORT > WIND CHILL
> HEAT INDEX > DEWPOINT**

i In **Normal Mode**, press **°F/°C** to switch between °C/°F.

Operation and Settings (continued)

Weather Index (continued)

UV Index: This reflects UV data collected by the **6-in-1 Wireless Outdoor Sensor** that the detectable range is 0~16.

Setting UV Index Gain, Sensor

Manufacturing Gain: Please reference your **6-in-1 Wireless Outdoor Sensor** battery compartment for any reference to gain adjustment. In this example shown, a gain of 1.7 must be entered into the **Main Console**.

1. In **Normal Mode** on the **Main Console**, press and hold **INDEX** for 10 seconds to enter into **UV Index Calibration Mode**.
2. Use **^** or **v** to adjust the UV gain magnification factor.
3. Press **INDEX** twice to confirm and exit.

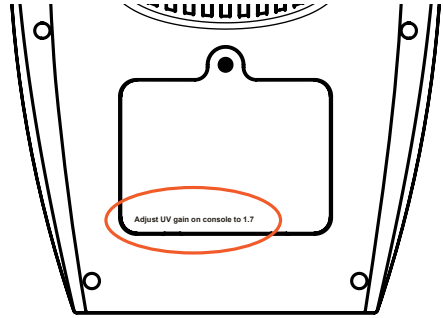

- i** The default UV gain magnification factor is 1.0, and can be adjusted up or down in increments of 0.1

Beaufort Scale: This is an international scale of wind velocities ranging from 0 (calm) to 12 (Hurricane force).

Beaufort Scale	Description	Wind Speed	Land Condition
0	Calm	< 1 km/h	Calm. Smoke rises vertically.
		< 1 mph	
		< 1 knots	
		< 0.3 m/s	
1	Light air	1.1 ~ 5km/h	Smoke drift indicates wind direction. Leaves and wind vanes are stationary.
		1 ~ 3 mph	
		1 ~ 3 knots	
		0.3 ~ 1.5 m/s	
2	Light breeze	6 ~ 11 km/h	Wind felt on exposed skin. Leaves rustle. Wind vanes begin to move.
		4 ~ 7 mph	
		4 ~ 6 knots	
		1.6 ~ 3.3 m/s	
3	Gentle breeze	12 ~ 19 km/h	Leaves and small twigs constantly moving, light flags extended.
		8 ~ 12 mph	
		7 ~ 10 knots	
		3.4 ~ 5.4 m/s	

Operation and Settings (continued)

Weather Index (continued)

Beaufort Scale	Description	Wind Speed	Land Condition
4	Moderate breeze	20 ~ 28 km/h	Dust and loose paper raised. Small branches begin to move.
		13 ~ 17 mph	
		11 ~ 16 knots	
		5.5 ~ 7.9 m/s	
5	Fresh breeze	29 ~ 38 km/h	Branches of a moderate size move. Small trees in leaf begin to sway.
		18 ~ 24 mph	
		17 ~ 21 knots	
		8.0 ~ 10.7 m/s	
6	Strong breeze	39 ~ 49 km/h	Large branches in motion. Whistling heard in overhead wires. Umbrella use becomes difficult. Empty plastic bins tip over.
		25 ~ 30 mph	
		22 ~ 27 knots	
		10.8 ~ 13.8 m/s	
7	High wind	50 ~ 61 km/h	Whole trees in motion. Effort needed to walk against the wind.
		31 ~ 38 mph	
		28 ~ 33 knots	
		13.9 ~ 17.1 m/s	
8	Gale	62 ~ 74 km/h	Some twigs broken from trees. Cars veer on road. Progress on foot is seriously impeded
		39 ~ 46 mph	
		34 ~ 40 knots	
		17.2 ~ 20.7 m/s	
9	Strong gale	75 ~ 88 km/h	Some branches break off trees, and some small trees blow over. Construction /temporary signs and barricades blow over.
		47 ~ 54 mph	
		41 ~ 47 knots	
		20.8 ~ 24.4 m/s	
10	Storm	89 ~ 102 km/h	Trees are broken off or uprooted, structural damage likely.
		55 ~ 63 mph	
		48 ~ 55 knots	
		24.5 ~ 28.4 m/s	
11	Violent storm	103 ~ 117 km/h	Widespread vegetation and structural damage likely.
		64 ~ 73 mph	
		56 ~ 63 knots	
		28.5 ~ 32.6 m/s	
12	Hurricane force	≥ 118 km/h	Severe widespread damage to vegetation and structures. Debris and unsecured objects are hurled about.
		≥ 74 mph	
		≥ 64 knots	
		≥ 32.7m/s	

Operation and Settings (continued)

Weather Index (continued)

Wind Chill: A combination of the **6-in-1 Wireless Outdoor Sensor** temperature and wind speed data determines the current wind-chill factor.

Heat Index: The heat index, which is determined by the **6-in-1 Wireless Outdoor Sensor** temperature and humidity data, when the temperature is between 27°C (80°F) and 50°C (120°F).

Heat Index range	Warning	Explanation
27°C to 32°C (80°F to 90°F)	Caution	Possibility of heat exhaustion
33°C to 40°C (91°F to 105°F)	Extreme Caution	Possibility of heat dehydration
41°C to 54°C (106°F to 129°F)	Danger	Heat exhaustion likely
≥55°C (≥130°F)	Extreme Danger	Strong risk of dehydration / sun stroke

Dew Point: The dew point is the temperature below which the water vapour in air at constant barometric pressure condenses into liquid water at the same rate at which it evaporates. The condensed water is called dew when it forms on a solid surface. The dew point temperature is determined by the temperature and humidity data from the **6-in-1 Wireless Outdoor Sensor**.

Weather Forecast

The **Main Console** is built with a sensitive pressure sensor, by which the proven sophisticated software forecasts the weather of the next 12~24 hours within a 30~50km (19~31 miles) radius.

- i The weather forecast is reflecting the weather situation for next 12 hours, it may not necessarily reflect the current situation.
- i The “Snowy” icon will be displayed when the outdoor temperature is below -3°C (26°F), and under cloudy or rainy forecast.

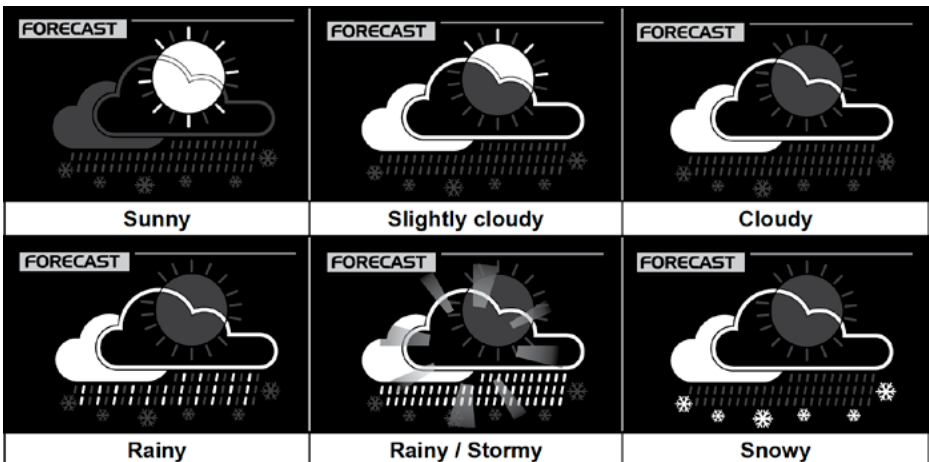

Operation and Settings (continued)

Barometric Pressure

Barometric Pressure is the atmospheric pressure is the pressure at any location of the Earth caused by the weight of the column of air above it. One atmospheric pressure refers to the average pressure and gradually decreases as altitude increases. Meteorologists use barometers to measure atmospheric pressure. Since variation in atmospheric pressure greatly affected by weather, it is possible to forecast the weather by measuring the changes in pressure.

To set the barometer unit and select the Wind Display Mode:

1. In **Normal Mode**, press **BARO** to change the barometer unit in this sequence: **hPa** > **inHg** > **mmHg**
2. In **Normal Mode**, press and hold **BARO** to switch between **ABSOLUTE/RELATIVE** display.

Absolute	The absolute atmospheric pressure of your location.
Relative	The relative atmospheric pressure based on the sea level

To set the **RELATIVE** atmospheric pressure value:

1. Obtain the atmospheric pressure data of sea level (it is also the relative atmospheric pressure data of your home area) through the local weather service, internet or any weather information source.
 2. In **Normal Mode**, press and hold **BARO** for 2 seconds until **ABSOLUTE** or **RELATIVE** icon flashes.
 3. Press **^** or **v** to switch to **Relative Mode**.
 4. Press **BARO** once again, relative atmospheric pressure digit flashes.
 5. Press **^** or **v** to change the value.
 6. Press **BARO** to save and exit.
- i** When you change the **RELATIVE** atmospheric pressure value, the weather indicators will change along with it.
 - i** The built-in barometer detects the environmental absolute atmospheric pressure changes. Based on the data collected, it predicts the weather conditions in the forthcoming 12 hours. The weather indicator will change according to the detected absolute atmospheric pressure after operating the clock for 1 hour.
 - i** The **RELATIVE** atmospheric pressure is based on the sea level pressure you entered but it will change with the absolute atmospheric pressure after operating the clock for 1 hour.

Rainfall

Setting Rainfall units:

1. Press and hold **RAINFALL** for 2 seconds to enter **Unit Setting Mode**.
2. Press **^** or **v** to toggle between millimetres and inches.
3. Press **RAINFALL** to confirm and exit the setting.

Select Rainfall Display Mode:

Press **RAINFALL** to toggle between:

- ✓ **DAILY**: Total rainfall from midnight
- ✓ **HOURLY**: Total rainfall in the past hour
- ✓ **WEEKLY**: Total rainfall for current week
- ✓ **MONTHLY**: Total rainfall for current calendar month
- ✓ **ACCUMULATE**: Total rainfall since last reset

- i** In **Normal Mode**, hold **HISTORY** for 2 seconds to reset the Accumulate rainfall record.

Operation and Settings (continued)

History Graph

To view different graphs: In **Normal Mode**, press **GRAPH** to toggle between different types of graph.

Weather variable	Unit of measure	Record time range	Graph
Barometric pressure	hPa, inHg and mmHg	Past 72 hours	
Indoor temperature (according to the current channel)	°F or °C	Past 72 hours	
Outdoor temperature	°F or °C	Past 72 hours	
Indoor humidity (according to the current channel)	%	Past 72 hours	
Outdoor humidity	%	Past 72 hours	
Rainfall	mm or in	Past 7 days (daily)	

Operation and Settings (continued)

History Graph (continued)

To view the daily MAX/MIN: The **Main Console** can record the daily MAX/MIN weather data for your easy review.

- i In **Normal Mode**, press **MAX/MIN** to check the daily MAX/MIN records. The display sequence is:
 - OUTDOOR MAX TEMPERATURE AND HUMIDITY**
 - > OUTDOOR MIN TEMPERATURE AND HUMIDITY**
 - > CURRENT CHANNEL INDOOR MAX TEMPERATURE AND HUMIDITY**
 - > CURRENT CHANNEL'S INDOOR MIN TEMPERATURE AND HUMIDITY**
 - > MAX AVERAGE WIND SPEED**
 - > MAX GUST**
 - > MAX DEW POINT**
 - > MIN DEW POINT**
 - > MAX WIND CHILL**
 - > MIN WIND CHILL**
 - > MAX HEAT INDEX**
 - > MIN HEAT INDEX**
 - > MIN HEAT INDEX**
 - > MAX UV INDEX**
 - > MAX BEAUFORT**
 - > MAX PRESSURE**
 - > MIN PRESSURE**
 - > MAX DAILY RAINFALL**
 - > MIN HEAT INDEX**

- i Press and hold **MAX/MIN** for 2 seconds to reset all the MAX/MIN records.

To view the history data (past 24 hours):

The **Main Console** automatically stores the weather data of the past 24 hours.

1. Press **HISTORY** to check the beginning of the current hour's weather data.
e.g. the current time is 7:25 am, March 28, the display will show the data of 7:00am, March 28.
 2. Press **HISTORY** repeatedly to view older readings of the past 24 hours.
e.g. 6:00am (Mar 28), 5:00am (Mar 28), ..., 10:00am (Mar 27), 9:00am (Mar 27), 8:00am (Mar 27)
- i The LCD will display the history data records and their time and date.

Weather Alert Setting

Setting alerts: Weather Alert can alert you of certain weather conditions. Once the alert criterion is met, the alarm sound will activate and the LCD alert icon will flash.

1. Press **ALERT** to select and display the desired weather alert reading in the sequence below:

Alert reading Sequence	Setting Range	Display Section	Default Value
Outdoor Temperature High Alert	-40°C ~ 80°C	Outdoor temperature & humidity section (OUTDOOR)	40°C
Outdoor Temperature Low Alert			0°C
Outdoor Humidity High Alert	1% ~ 99%		80%
Outdoor Humidity Low Alert			40%
Indoor Temperature High Alert	-40°C ~ 80°C	Current Indoor temperature & humidity section (INDOOR)	40°C
Indoor Temperature Low Alert			0°C
Indoor Humidity High Alert	1% ~ 99%		80%
Indoor Humidity Low Alert			40%
Wind Speed	0.1m/s ~ 50m/s	Wind direction & speed section (WIND)	17.2mm/h
Pressure Drop (within 30 minutes)	1hPa ~ 10hPa	Barometer section (BARO)	3hPa
Daily Rainfall	1mm ~ 1000mm	Rainfall section (RAINFALL)	100mm

Operation and Settings (continued)

Weather Alert Setting (continued)

- Under the current alert reading, press and hold **ALERT** for 2 seconds to enter alert setting and the alert reading will flash.
- Press **▲** or **▼** key to adjust the value or press and hold the key to change rapidly.
- Press **ALERT** key to save the alert reading then press **ALARM** to toggle the regarding alert on/off.
- Press any key on the front side to save and back to **Normal Mode**.



- i** To silence the alert alarm, press **ALARM/SNOOZE**.
- i** Once the alert is triggered, the alarm will sound for 2 minutes and the related alert icon will flash.
- i** The weather alert will sound again when the weather readings falls into the alert range again.

Pointing Outdoor Sensor to South

The **6-in-1 Wireless Outdoor Sensor** is calibrated to point to North for the maximum accuracy. However, for the user's convenience (e.g. users in the Southern hemisphere), it is possible to use the sensor with the wind vane pointing to South.

- Install the **6-in-1 Wireless Outdoor Sensor** with its wind meter end pointing South.
 - In **Normal Mode** on the **Main Console**, press and hold **INDEX** for 8 seconds to enter **UV Index Calibration Mode**, then press **INDEX** again until the **N** icon appears on the weekday location to enter **Sensor Orientation Mode**.
 - Use **▲** or **▼** to change to lower part (Southern Hemisphere).
 - Press **INDEX** to confirm and exit.
 - Press **REFRESH** to sync the internet time after you complete the setting.
- i** Changing the hemisphere setting will automatically switch the direction of the moon phase on the display.

Maintenance

Battery Replacement

- i** When the low battery indicator  displays, it indicates that the **6-in-1 Wireless Outdoor Sensor** or the **Wireless Hygro-Thermo Indoor Sensor** battery power is low. You should replace these with fresh AA size batteries at once.

Maintenance (continued)

Cleaning the Rain Collector

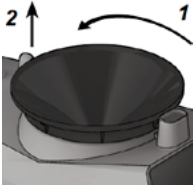

1. Unscrew the rain collector by turning it 30° anticlockwise.
2. Gently remove the rain collector.
3. Clean and remove any debris or insects.
4. Install the collector when it is clean and fully dried.

Cleaning the Outdoor Hygro-Thermo Sensor

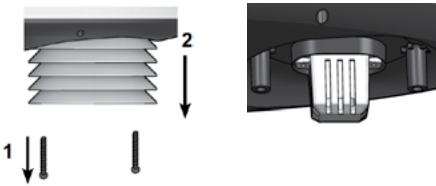

1. Remove the 2 screws at the bottom of the louvre shield.
2. Gently pull out the shield.
3. Carefully remove any dirt or insects on the sensor casing (do not let the sensors inside get wet).
4. Clean the shield with water to remove any dirt or insects.
5. Install all the parts back when they are clean and fully dried.

Cleaning The UV Sensor and Calibration

Clean the UV sensor cover lens: For precision UV measurement, gently clean the UV sensor cover lens with pure water regularly.

UV Sensor Degradation: Over time, the UV sensor will naturally degrade. This can be calibrated with a utility grade UV meter.

Main Console Firmware Update

1. Unzip the *Update.zip* file and copy the unzipped *Update* folder to a USB drive.
 - ❗ The USB drive must be FAT32 format and the *Update* folder must be in the root directory of the USB drive
2. Disconnect the **Main Console** DC power from the power outlet and remove the backup batteries. Plug the USB mass storage driver to the USB socket at the right side of the **Main Console**.
3. Reconnect the **Main Console** DC power to start the update process.
 - ❗ Do not remove the USB drive during update. If the firmware update does not restart, press **RESET** to trigger the update process.
4. During the update process, the **Main Console** status LED will flash in red and LCD panel will show the update status as below:

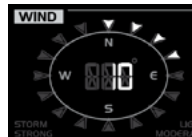

UPDATING SCREEN

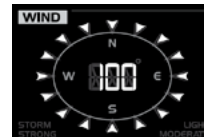

UPDATE COMPLETE +
WAITING FOR REBOOT

5. Once the update is complete, the **Main Console** will restart and return to the normal display screen.
6. Remove the USB drive from the **Main Console**.
7. Set the time zone on the **Main Console**.
8. Enter the [Weather Underground](#) connection information and set the time server in the setup UI.
 - ❗ The USB port is for firmware updates only.
 - ❗ Please keep power connected during the firmware update process.
 - ❗ During update process, the Wi-Fi will be disabled until update success. If the **Main Console** cannot connect to your router, you need to re-enter the router and [Weather Underground](#) connection information and set time server in the setup UI again.

Maintenance (continued)

Precautions

- i** Read and keep these instructions
- i** Do not subject the unit to excessive force, shock, or dust
- i** Do not cover the ventilation holes with any items such as newspapers, curtains etc.
- i** Do not immerse the unit in water. If you spill liquid over it, dry it immediately with a soft, lint free cloth
- i** Do not clean the unit with abrasive or corrosive materials
- i** Do not tamper with the unit's internal components. This invalidates the warranty
- i** Only use fresh batteries. Do not mix new and old batteries
- i** Only use attachments/accessories specified by the manufacturer
- i** Images shown in this manual may differ from the actual display
- i** Placement of this product on certain types of wood may result in damage to its finishing for which manufacturer will not be responsible. Consult the furniture manufacturer's care instructions for information
- i** The contents of this manual may not be reproduced without the permission of the manufacturer
- i** When replacement parts are required, be sure the service technician uses replacement parts specified by the manufacturer that have the same characteristics as the original parts
- i** Unauthorised substitutions may result in fire, electric shock, or other hazards
- i** Do not dispose old batteries as unsorted municipal waste. Collection of such waste separately for special treatment is necessary
- i** The socket outlet shall be installed near the equipment and shall be easily accessible
- i** Technical specifications and user manual contents for this product are subject to change without notice
- i** Place the **Main Console** at least 20cm from nearby persons

Specifications

Main Console

The following details are listed as they are displayed or operate on the **Main Console**

General	
Dimensions (W×H×D)	215 × 172 × 29mm (8.5 × 6.8 × 1.1in)
Weight	639g (with batteries)
Main power	DC 5V, 1A adaptor
Backup battery	3 × AAA size 1.5V batteries (alkaline recommended)
Operating temperature range	-5°C ~ 50°C
Wi-Fi	
Wi-Fi standard	802.11 b/g/n
Wi-Fi operating frequency	2.4GHz
Supported device for setup UI	Built-in Wi-Fi with AP Mode function smart devices, laptops or desktops: Android smart phone, Android pad, iPhone, iPad or Windows laptop
Recommended web browser for setup UI	Web browsers that support HTML 5, such as the latest version of Chrome, Safari, IE, Edge, Firefox or Opera.
Wireless Sensor	
Support sensors	1 Wireless 6-in-1 weather outdoor sensor and up to 7 Wireless Hygro-Thermo indoor sensors
RF frequency	917Mhz (AU version)
RF transmission range	150m
Time	
Time display	HH:MM:SS
Hour format	12hr AM/PM or 24hr
Date display	DD/MM or MM/DD
Time synchronise method	Through Internet time server to synchronise the UTC
Weekday languages	EN/DE/FR/ES/IT/NL/RU
Hour offset	+13 ~ -12 hour
DST	ON/OFF

Barometer	
Barometer unit	hPa, inHg and mmHg
Measuring range	540 ~ 1100hPa (relative setting range 930 ~ 1050hPa)
Accuracy	(700 ~ 1100hPa ± 5hPa)/(540 ~ 696hPa ± 8hPa) (20.67 ~ 32.48inHg ± 0.15inHg)/(15.95 ~ 20.55inHg ± 0.24inHg) (525 ~ 825mmHg ± 3.8mmHg)/(405 ~ 522mmHg ± 6mmHg) Typical at 25°C (77°F)
Resolution	1hPa/0.01inHg/0.1mmHg
Weather forecast	Sunny/Clear, Slightly Cloudy, Cloudy, Rainy, Rainy/Stormy and Snowy
Display modes	Current
Memory modes	Historical data of past 24 hours, daily Max/Min
Alarm	Pressure change alert
Indoor/Outdoor Temperature	
Temperature unit	°C and °F
Display range	-40 ~ 80°C (-40 ~ 176°F)
Accuracy	55 ~ 60°C ± 0.5°C (131 ~ 140°F ± 0.9°F) 10 ~ 55°C ± 0.4°C (50 ~ 131°F ± 0.7°F) -20 ~ 10°C ± 1.3°C (-4 ~ 50°F ± 2.3°F) -40 ~ -20°C ± 1.9°C (-40 ~ -4°F ± 3.4°F)
Resolution	0.1°C/0.1°F
Display modes	Current
Memory modes	Historical data of past 24 hours, daily Max/Min
Alarm	Hi/Lo temperature alert
Indoor/Outdoor Humidity	
Humidity unit	%
Display range	0 ~ 100%
Accuracy	0 ~ 90% RH ± 2.5% RH @ 25°C (77°F) 90 ~ 100% RH ± 3.5% RH @ 25°C (77°F)
Resolution	1%
Display modes	Current
Memory modes	Historical data of past 24 hours, daily Max/Min
Alarm	Hi/Lo Humidity Alert

Specifications (continued)

Main Console (continued)

The following details are listed as they are displayed or operate on the **Main Console**

Indoor/Outdoor Humidity	
Wind speed unit	<i>mph, m/s, km/h and knots</i>
Wind speed display range	<i>0 ~ 112mph, 50m/s, 180km/h, 97knots</i>
Resolution	<i>0.1mph, 0.1m/s, 0.1km/h, 0.1knots</i>
Speed accuracy	<i>±2.2 mph or ±10% (whichever is greater)</i>
Display mode	<i>Gust/Average</i>
Memory modes	<i>Historical Data of past 24 hours, daily Max Gust/Average</i>
Alarm	<i>Hi Wind Speed Alert (Average/Gust)</i>
Wind direction resolutions	<i>1 degree</i>
Rain Display	
Unit for rainfall	<i>mm and in</i>
Accuracy for rainfall	<i>± 7%</i>
Range of rainfall	<i>0 ~ 19999mm (0 ~ 787.3 in)</i>
Resolution	<i>0.254mm (0.01in)</i>
Display modes	<i>Current</i>
Memory modes	<i>Historical Data of the past 24 hours, daily Max</i>
Rainfall display mode	<i>Hourly/Daily/Weekly/Monthly/Total rainfall</i>
Alarm	<i>Hi Daily Rainfall Alert</i>
Weather Index	
Weather index mode	<i>UV Index, Beaufort, Wind Chill, Heat Index and Dew point</i>
UV index range	<i>0 ~ 16</i>
Beaufort scale	<i>0 ~ 12</i>
Wind Chill range	<i>-40 ~ 18°C, wind speed >4.8km/h</i>
Heat index range	<i>26 ~ 50 °C</i>
Dew point range	<i>-20 ~ 60°C</i>
Display modes	<i>Current</i>
Memory modes	<i>Historical Data of past 24 hours, Daily Max/Min</i>

6-in-1 Wireless Outdoor Sensor

General	
Dimensions (W × H × D)	<i>392.5 × 326 × 144.5mm (15.5 × 12.8 × 5.7in)</i>
Weight	<i>1096g (with batteries)</i>
Main power	<i>3 × AA size 1.5V batteries (Alkaline batteries recommended)</i>
Auxiliary power	<i>Solar panel</i>
Weather data	<i>Temperature, Humidity, Wind speed, Wind direction, Rainfall and UV index</i>
RF transmission range	<i>150m</i>
RF frequency	<i>917Mhz (AU)</i>
Transmission interval	<i>12 seconds for wind speed and wind direction data, 24 seconds for temperature, humidity, UV and rain data</i>
Operating range	<i>-40 ~ 60°C (-40 ~ 140°F) Lithium batteries required</i>

Wireless Hygro-Thermo Indoor Sensor

General	
Dimensions (W × H × D)	<i>61 × 113 × 39.5mm (2.4 × 4.4 × 1.6in)</i>
Weight	<i>144g (with batteries)</i>
Main power	<i>2 × AA size 1.5V batteries (alkaline recommended)</i>
Weather data	<i>Temperature and humidity</i>
RF frequency	<i>917Mhz (AU)</i>
RF transmission range	<i>150m</i>
Transmission interval	<i>60 seconds</i>
Operating range	<i>-40 ~ 60°C (-40 ~ 140°F) Lithium batteries required</i>

Weather Underground is a registered trademark of The Weather Channel, LLC, both in the United States and internationally. The Weather Underground Logo is a trademark of Weather Underground, LLC.



**Should you have any questions about this product or its operation
please telephone our customer service helpline on 1300 716 188.**

HOLMAN

For the #SMARTGARDENER   

Head Office/Service

11 Walters Drive, Osborne Park WA 6017
Ph: +61 8 9416 9999 Fax: +61 8 9416 9920
service@holmanindustries.com.au
www.holmanindustries.com.au